



JAG-CD

QUICK START INSTALLATION GUIDE FOR JAGUAR X308 AND X100 WITH CD CHANGER

1997-99 Standard or Premium Audio System & 2000-06 Standard Audio System
(NOT for 2000-Up Premium Audio System)

Created May 3, 2016

Revised: September 11, 2021

PRODUCT SAFETY & DISCLAIMER

READ ALL INSTRUCTIONS CAREFULLY BEFORE INSTALLING, FAILURE TO DO SO MAY CAUSE PERSONAL INJURY OR DAMAGE TO PRODUCT AND/OR PROPERTY

- This installation guide is provided as a GENERAL installation guide, some vehicles vary and may require additional steps. We do not accept responsibility for third party labor charges or modifications. Exercise due-diligence when installing this product.
- We do not accept any responsibility for vehicle damage or personal injury resulting from the installation of this product.

Careless installation and operation can result in equipment damage

Requirements

CD AUTO CHANGER

Introduction

Those Jaguar owners who are adamant about hanging on to the original radio and audio system we offer a line of adapters that sure to open up a whole lot of different options for listening to music and other audio content. The JAG-CD adapter provides a 3.5mm Audio jack which can be used to connect and play all kinds of audio devices including Smartphones, MP3 Players, iPods, Zune, iPads etc. The JAG-CD auxiliary input adapter does not control or charge audio device and connects to the back of the radio in **late 1997-99 XJ (X308) and XK (X100) Standard OR Premium Audio Systems** and **2000-03 XJ (X308) and 2000-06 XK (X100) Standard Audio Systems only**. See **Frequently Asked questions** at the end of this guide for more details.

Installation

Warning: The JAG-CD connects to **the radio** (not to Changer) and radio removal is required. **All 2000-03 x308 and 2000-06 x100 premium sound system (amplifier) requires the JAG-CDR**

This step may not be necessary but we recommend disconnecting the Negative Battery Terminal (See Fig. 1)

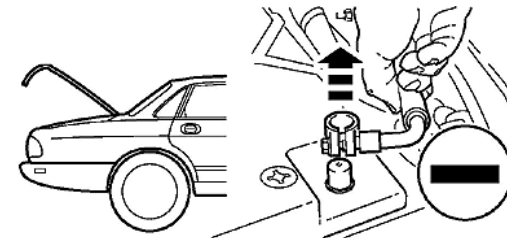

Fig. 1

1. Move "J" gate selector to position "D"
2. Using a panel removal tool, unclip and remove "J" gate finisher (See Fig. 2)

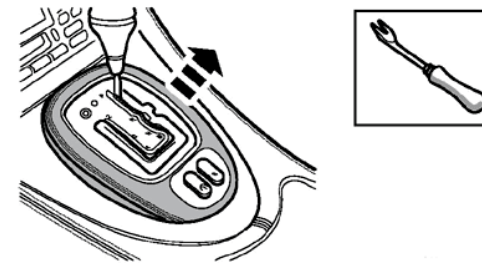

Fig. 2

3. Using a T30 torx head, remove "J" gate finisher plate (See Fig. 3)

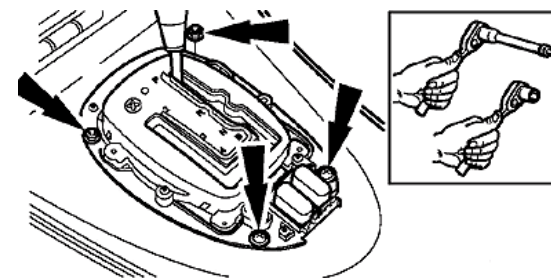
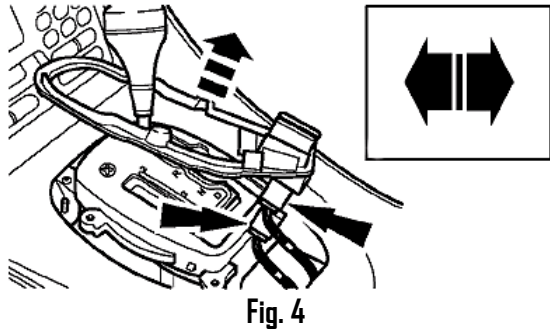
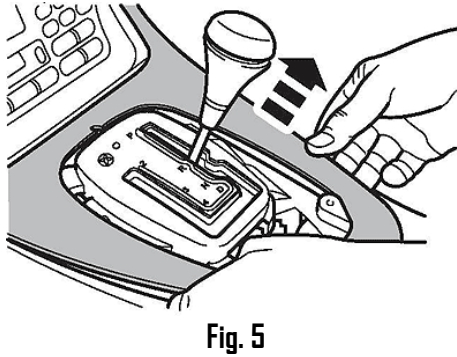

Fig. 3

4. Lift finisher plate upwards and disconnect electrical plugs (See Fig. 4)



5. Remove center console veneer panel (See Fig. 5)



6. Remove (2) Philips head screws on LH and RH side of console (See Fig. 6)

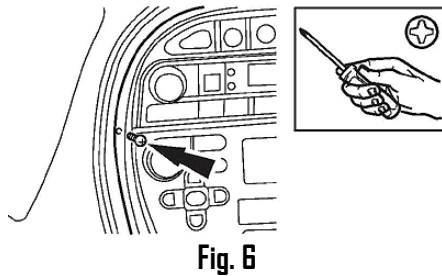

7. Lift radio over gear selector hub and remove from dash (See Fig. 7).

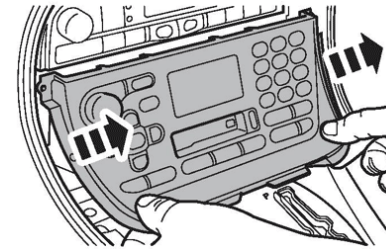

8. Disconnect CD changer plug from radio as seen in Fig. 8

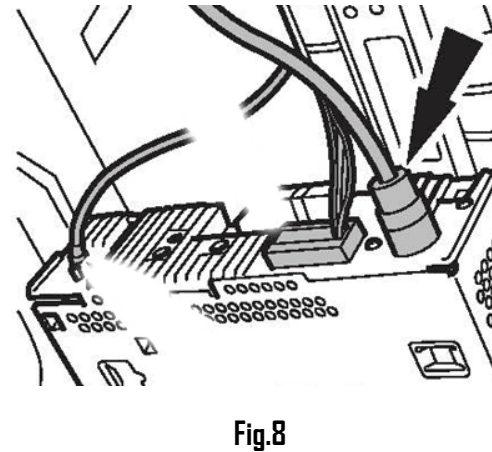

9. Connect CD changer male plug (from step 8) into female connector on the adapter box. (See Fig. 9)



Fig. 9
Adapter connections

Warning: Single DIN radios (e.g. LJB4100BA) most XK vehicles the radio **ground strap** (See Fig. 9a) may need to be relocated. This applies only to single DIN radios in non-premium vehicles with ground strap.



Fig. 9a

10. Connect adapter male plug to radio CD port (**don't force, twist or wiggle**)
11. Carefully route audio jack (See Fig. 10) to front of dashboard or nearby location to be mounted (within 4 ft.). Mounting location will vary based on vehicle and customer's preference.



Fig. 10
Audio Jack

12. Drill a 1/4" (6.35mm) hole at chosen location and secure jack to dash with nut (See Fig.11)



Fig. 11

Warning: Should you decide to mount audio jack, make sure mounting panel is no thicker than **1/8"** for jack shaft to engage with nut. (If necessary, use a Dremel or sander to thin panel). Mounting audio jack is not necessary but doing so makes for a stock appearance and easier to connect and disconnect your audio devices.

Operation

1. Turn radio ON.
2. Press "CD" button. Track/Disc number will be displayed only if there is a disc in magazine otherwise "NO MAGAZINE" is displayed (See Fig. 12)



Fig. 12

3. Connect audio device to 3.5mm jack using Free 3 ft. Audio cable (See Fig. 12).



Fig. 12

3.5mm male to male cable

4. Place audio device in playback mode. This interrupts CD changer Playback and music from Audio device will play on car speakers.
5. Use radio volume control button to set playback level and audio device volume setting to match CD or radio playback levels.
- 6.

Warning: Song display, playlist and Track selection is *NOT* possible from radio. Must use audio devices built-in controls to access audio files.

7. To listen to the CD changer, simply **disconnect the 3.5mm audio cable from the jack** and operate changer as customary (Jack must be empty during CD changer playback otherwise playback may include noise or buzz)
8. If correct operation is confirmed go ahead and reinstall radio

Frequent ask question

1. **Does the JAG-CD work in Premium Systems?**
YES; works in late 1997-99 XK (X100) and 1998-99 XJ (X308) Premium Audio, **NOT compatible with 2000-06 XK (X100) nor 2000-03 XJ (X308) Premium Sound Systems.** These require the **JAG-CDR**. **In other words, the JAG-CD is not compatible with 2000-Up with Premium Audio.**
2. **How do I know if vehicle has a Premium Sound System?**
- **Premium Sound System** has an amplifier mounted atop audio rack in trunk: To check simply remove driver side carpet panels to reveal audio rack. (See picture below).



- If vehicle has subwoofer mounted to rear deck (Sedan) or rear side panels (convertible), this also indicates vehicle has amplifier.
3. **Can I contact DiscountCarStereo.com to find out which sound system is present in my vehicle?**
Unfortunately we will not be able to tell your sound system. See question #2 to determine sound system prior to purchasing these parts.
4. **What's the difference between your JAG-CD and JAG-CDR?**
The JAG-CDR connects to CD changer in trunk/hatch and works in both premium and standard **Audio Systems**. The JAG-CD connects to the radio and compatible with 1997-99 XK (X100) and XJ (X308) **Standard or Premium** audio systems and also work in 2000-03 XJ (X308) and 2000-06

XK (X100) **Standard Audio Systems only.** (Not for 2000+ Premium Systems)

5. **Can I install the JAG-CD without removing the radio?**
NO; the JAG-CD must be connected to radio.
6. **In which model/years will the JAG-CD work and where does it connect?**
The JAG-CD is specific to the following vehicles and connects to the radio (Not to CD plug in trunk/hatch)
1998-99 XJ (X308) **Premium System- connects to radio**
1998-03 XJ (X308) **Standard Sound System- connects to radio**
1997*-99 XK (X100) **Premium Sound System—connects to radio**
1997*-06 XK (X100) **Standard Sound System—connects to radio**

Warning: 2000-03 x308 and 2000-06 x100 Premium Sound systems requires the JAG-CDR (which connects only to Changer in trunk)

7. **Will I be able to connect the JAG-CD to the CD Changer instead of the radio?**
NO; The JAG-CD connects to the radio and **will not work** if connected to CD Changer plug. 2000-Up Premium system requires the **JAG-CDR**.

*Late 1997 with Ai-net plug (not for early 1997 with 8-pin plug)

Disclaimer

- This product has no affiliation with Jaguar or Apple
- There are no warranties expressed or implied by purchase of this product
- We're not liable for misuse of this product.

Email support@discountstereo.com

© 1995-Sep-21 Discount Car Stereo, Inc. All rights reserved. Information in this document is subject to change without notice. Other products and companies referred to herein are trademarks or registered trademarks of their respective companies or mark holders.